

CROWN

PTH 50

Series



Functional, robust and dependable.

The PTH 50 Series carries the weight of our reputation. Crown is one of the largest manufacturers of electrically powered lift trucks in the world. Our customers rely on us for robust, functional product design and long-term dependability. The PTH 50 Series hand pallet trucks also feature these traits, and with over 1.5 Million trucks sold worldwide, our reputation is an important part of each unit that we sell. We are determined to build the finest quality trucks offering real long-term value to our customers. We realise that if you purchase our hand pallet trucks, this may be your first experience using a Crown product. We want this to be a positive one. For this reason, we have designed into each truck many standard features that will help your operator be more productive.



1 Full-function control handle with neutral

A few strokes of the large steering handle provides a full 127 mm of lift. A convenient control lever has three positions: Raise, Neutral and Lower. The neutral position eliminates backpressure from the pump, allowing the handle to move freely. Lowering speed is controlled at all load capacities. The handle is spring loaded and returns to a vertical position when released. The handle thickness and angled shape is designed for the most fatigue free operating position.



2 Hydraulic unit proven reliability

One of the most critical parts of a hand pallet truck is the hydraulic pump. It must withstand thousands of lift/lower cycles, and yet be easy and inexpensive to repair. The Crown PTH 50 is life tested to a minimum of 600,000 pump cycles. The totally enclosed lift pump means that there are no exposed springs, which can be broken or damaged.



3 Strong fork design

The C-channel fork design uses formed steel members with steel reinforcing at key stress areas.



Evidence of Crown's emphasis on reliability is apparent with the choice of box-section pushrods which are stronger and more durable than other pushrod designs. The proof is the full load capacity of 2300 kg with all fork lengths up to 2 m.

4 Durable frame and articulating wheels

A robust, cross-braced frame provides unrivalled strength and durability. Steel forgings are used on the lift linkage. For easier handling and control, the PTH has large 180 mm steer wheels. Steer and load wheels use high quality compounds that lower rolling resistance, provide long life, and are smooth and quiet in operation.

To ensure continuous contact with the floor, the wheels articulate to ensure you never have the weight of the load on just one wheel. Hubcaps protect the bearing and steer axle from side impact damage and contamination.

5 Easy pallet entry and exit

The fork tip and tapered mounting bracket design for the PTH entry roller affords protection for the roller itself and the load wheels.



The exit ramp, riser and the exit roller are engineered for long life and impact resistance. The combined effect for the operator is excellent entry and exit from pallets, even when the pallet is empty. A low 75 mm lowered fork height allows easy access to difficult or damaged pallets.

6 Long-term value

Crown utilizes high-grade steel combined with extra weld length and additional stiffening where necessary, especially in the area of apron pivot bosses. Thorough preparation of the assemblies before receiving a powder paint process ensures the highest levels of paint adhesion and long-term protection.



Service life

Crown has designed the PTH to be as maintenance free as possible. Features such as a strong, robust frame and linkage together with high quality forgings and welds ensure better longevity. The PTH features the extensive use of “sealed and lubricated for life” bushings and bearings where others feature grease fittings. The PTH hydraulic pump is fully serviceable and repairable. Each part is economical to replace and readily available.

Options

Crown engineered options include handbrake, galvanisation wet application treatment and a choice of wheel compounds. The PTH family also includes models with weighing scale and high-lift forks.



PTH with weighing scale

Measuring, checking and counting: The new PTH 50 WS weighs with extreme accuracy even with unevenly distributed loads and on irregular surfaces.



PTH with manual or powered scissor lift

Use it as a **hand pallet lift truck, storage table or workbench.** The PTH 50 S and PS save operator effort, avoiding unnecessary bending and heavy lifting.

PTH 50 Series

Hand Pallet Truck

Standard Specifications *

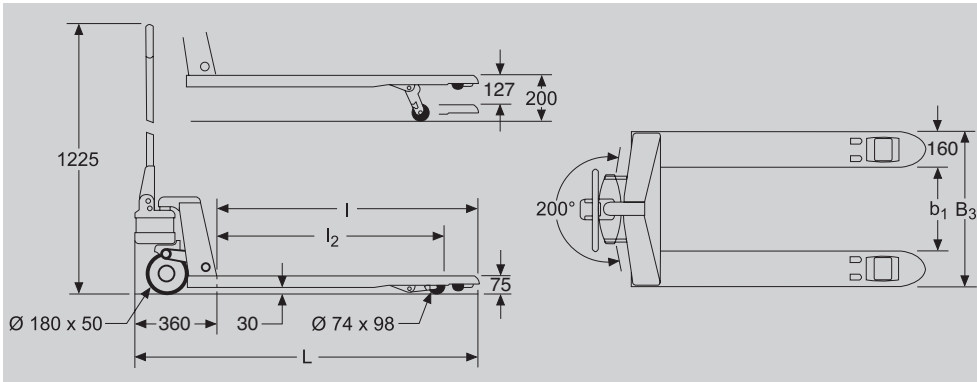

Model	PTH 50	
Capacity	2300 kg	
Headlength	L ₂	360 mm
Fork width	b	160 mm
Lift	h ₃	127 mm
Lowered fork height	S	75 mm
Lowered fork clearance	F	30 mm
Steer wheels	Poly	Ø 180 x 50 mm
Load wheels	Poly	Ø 74 x 98 mm

Model		PTH 18-32	PTH 18-39	PTH 18-45	PTH 20-32	PTH 20-39	PTH 20-45	PTH 27-32	PTH 27-39	PTH 27-45
Overall length	L	1155 mm	1350 mm	1510 mm	1155 mm	1350 mm	1510 mm	1155 mm	1350 mm	1510 mm
Fork length	l	795 mm	990 mm	1150 mm	795 mm	990 mm	1150 mm	795 mm	990 mm	1150 mm
Load wheel lowered	l ₂	648 mm	843 mm	1003 mm	648 mm	843 mm	1003 mm	648 mm	843 mm	1003 mm
Outside fork spread	B ₃	450 mm	450 mm	450 mm	520 mm	520 mm	520 mm	685 mm	685 mm	685 mm
Inside fork spread	b ₁	130 mm	130 mm	130 mm	200 mm	200 mm	200 mm	365 mm	365 mm	365 mm
Truck weight		55 kg	60 kg	64 kg	57 kg	62 kg	66 kg	61 kg	66 kg	70 kg

* Non-standard specifications also available.

Safety Regulations

Conforms to European safety standards.

Dimensions and performance data given may vary due to manufacturing tolerances. Performance is based upon an average size vehicle and is affected by weight, condition of truck, how it is equipped and the conditions of the operating area. Crown products and specifications are subject to change without notice.

Crown

European Headquarters

Moosacher Strasse 52
80809 Munich
Germany
Tel +49(0)89-93002-0
Fax +49(0)89-93002-133

German Locations:

Hamburg
Berlin
Hanover
Cologne
Dortmund
Frankfurt
Stuttgart
Nuremberg
Munich

Crown Handling NV

Satenrozen 12
2550 Kontich
Belgium
Tel +32(0)3-4507171
Fax +32(0)3-4507181

Crown Intern Transport BV

Damsluisweg 75
1332 EB Almere
Netherlands
Tel +31(0)36-5494180
Fax +31(0)36-5494276

Crown Lift Trucks Ltd.

Locations in United Kingdom:

Wokingham, Berkshire RG41 2JT
Tel +44(0)845-8509276
Fax +44(0)845-8509277

Warrington, Cheshire WA2 8TS
Tel +44(0)845-8509280
Fax +44(0)845-8509281

Almondsbury, Bristol BS32 4RX
Tel +44(0)845-8509268
Fax +44(0)845-8509269

Swindon, Wiltshire SN3 4TS
Tel +44(0)845-8509270
Fax +44(0)845-8509271

Bellshill, Lanarkshire ML4 3LX
Tel +44(0)845-8509265
Fax +44(0)845-8509266



www.crown.com

Because Crown is continually improving its products, specifications are subject to change without notice.

"Crown" and "Work Assist" are trademarks of Crown Equipment Corporation.

Copyright 2003 Crown Equipment Corporation
PTH50 BROCH GB 03/05, 50 - M01305-006-15
Printed in Germany