

**CROWN**

**Specifications**

**ESR 4500 Series**

Reach Truck

# ESR 4500

# Series



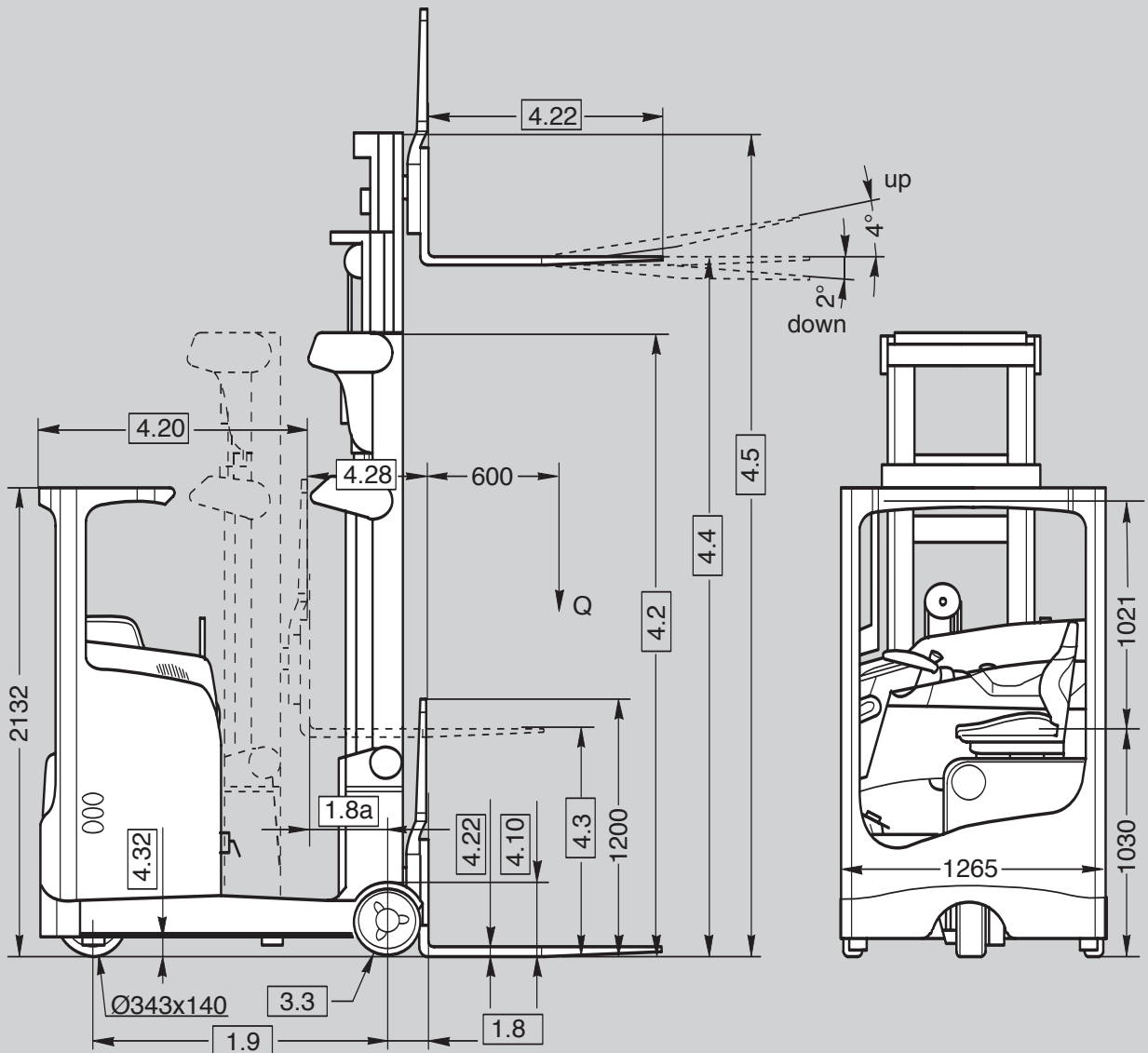
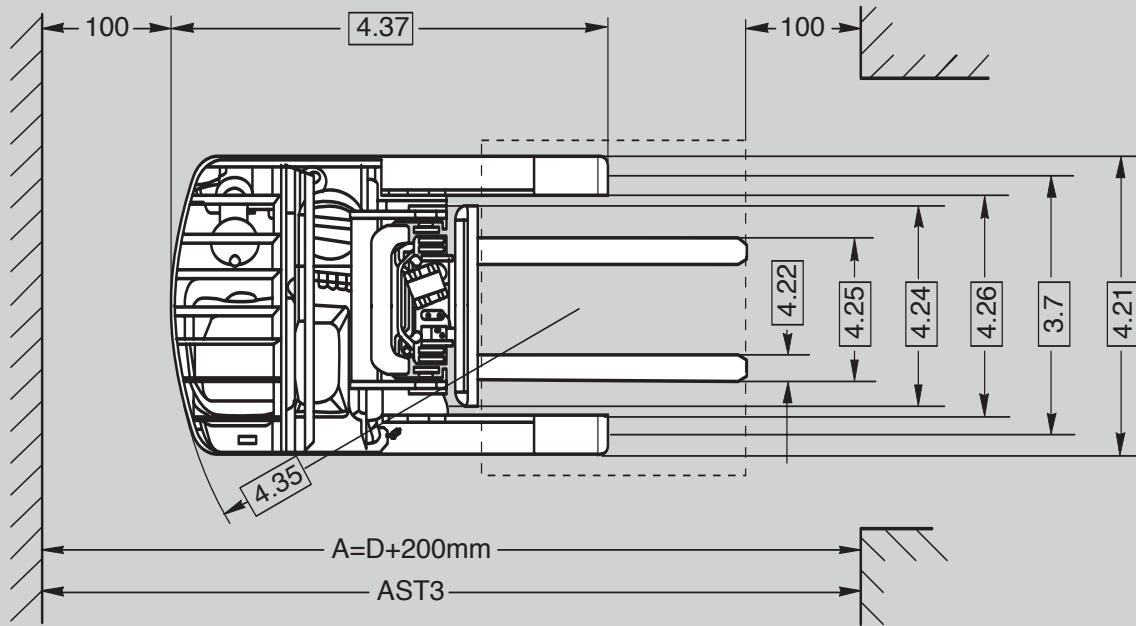

General Information	1.1	Manufacturer	Crown Equipment Corporation					
	1.2	Model			ESR 4500-1.4	ESR 4500-1.6	ESR 4500-2.0	
	1.3	Power	electric					
	1.4	Operator Type	rider / seat					
	1.5	Load Capacity	Q	t	1.4	1.6	2.0	
	1.6	Load Centre	c	mm	600			
	1.8a	Load Distance	mast retracted	x1	mm	see table of dimension 2		
	1.8	Load Distance	mast extended	x	mm	189	212	217
	1.9	Wheel Base		y	mm	1380	1475	1475
Weights	2.1	Weight	less battery		kg	2570 <sup>▲</sup>	2593 <sup>▲</sup>	2682 <sup>▲▲</sup>
	2.4	Axle Load	reach extended		kg	see table of dimension 3		
	2.5	Axle Load	reach retracted		kg	see table of dimension 3		
Tyres	3.1	Tyre Type	D/L			Vulkollan		
	3.2	Tyres	front		mm	343 x 140		
	3.3	Tyres	rear		mm	285 x 100	330 x 100	330 x 100
	3.5	Wheels	number (x = driven) front/rear			1x / 2		
	3.7	Track Width	rear	b11	mm	see table of dimension 1		
Dimensions	4.1	Forkcarriage Tilt	forward/backward	angle	°	2 / 4		
	4.2	Mast	collapsed height	h1	mm	see table of dimension 4		
	4.3	Free Lift*	w.o. load backrest	h2	mm	see table of dimension 4		
	4.4	Lift		h3	mm	see table of dimension 4		
	4.5	Mast**	extended height w.o. load backrest	h4	mm	see table of dimension 4		
	4.7	Overhead Guard Height		h6	mm	2132		
	4.8	Seat Height	compressed	h7	mm	1048		
	4.10	Outrigger Height			mm	301	346	346
	4.15	Lowered Fork Height		h13	mm	40	40	45
	4.16	Head Room	overhead guard		mm	1021		
	4.20	Headlength		l2	mm	see table of dimension 2		
	4.21	Overall Width	front/rear	b1/b2	mm	1265 / see table of dimension 1		
	4.22	Fork Dimensions		thxwxl	mm	40 x 100 x 1150	40 x 100 x 1150	45 x 100 x 1150
	4.23	Fork Carriage	ISO-class			2 A		
	4.24	Fork Carriage Width	w./w.o. load backrest	b3	mm	770 / 750		
	4.25	Width Across Forks		b5	mm	see table of dimension 1		
	4.26	Inside Straddle		b4	mm	see table of dimension 1		
4.28	Reach		l4	mm	see table of dimension 2			
4.32	Ground Clearance	centre wheelbase	m2	mm	76			
4.33	Working Aisle Width	1000 x 1200 travers lowered	Ast	mm	see table of dimension 2			
4.34	Working Aisle Width	800 x 1200 length lowered	Ast	mm	see table of dimension 2			
4.35	Turning Radius		Wa	mm	1645	1734	1734	
4.37	Length over Outriggers		l7	mm	1785	1903	1903	
Performance	5.1	Travel Speed	w./w.o. load		km/h	12.0 / 12.0		
	5.2	Lift Speed	w./w.o. load		m/s	0.41 / 0.69	0.39 / 0.69	0.32 / 0.54
	5.3	Lower Speed	w./w.o. load		m/s	0.57 / 0.57	0.57 / 0.57	0.57 / 0.50
	5.4	Reach Speed	w./w.o. load		m/s	0.19 / 0.19		
	5.7	Max. Gradeability	w./w.o. load		%	12 / 12		
	5.10	Service Brake				hydraulic		
Motors	6.1	Traction Motor	60 min. rating		kW	6.8		
	6.2	Lift Motor	15 % on time		kW	11.9		
	6.3	Max. Battery Box Size		lxhwx	mm	see table of dimension 2		
	6.4	Battery Voltage	nominal capacity 5h rating		V/Ah	48 / see table of dimension 2		
	6.5	Battery Weight	nominal +5%		kg	see table of dimension 2		
Misc.	8.1	Type of Controller	drive / lift / steer			transistor		
	8.2	Available Working Pressure f. Attachments			bar	165		
	8.4	Noise Level			dB(A)	65		

\* with load backrest 1.4 / 1.6 t -650 mm; 2.0 t -535 mm.

\*\* with load backrest 1.4 / 1.6 t +650 mm; 2.0 t +535 mm.

▲ 1.4 / 1.6 t with lift height 4890 + opt. 1 battery compartment tray

▲▲ 2.0 t with lift height 4595 + opt. 2 battery compartment tray

Table 1

3.7	Track width rear	b11	mm	1177	1317	1476
4.21	Overall width rear	b2	mm	1285	1425	1575
4.25	Width across forks, max.	b5	mm	750	750	980
4.26	Width inside straddle	b4	mm	965	1105	1255
	Sideshift movement	left / right	mm	70	70	100

Load Centre Capacity Chart

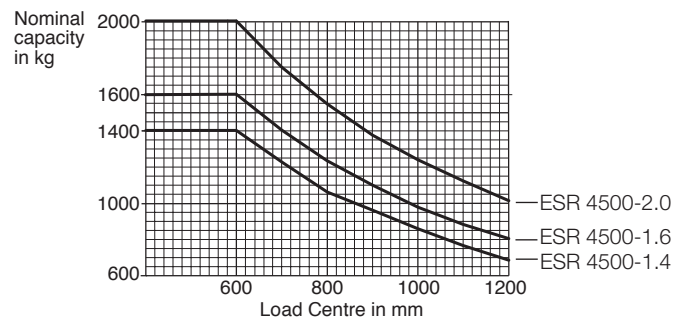

Table 2

6.4 Truck Specification 1285 mm Width (b2)	4.20 Headlength l <sub>2</sub>	1.8a Load Dist. x <sub>1</sub>	4.28 Reach l <sub>4</sub>	4.33 & 4.34				6.3 Battery Size l <sub>x</sub> h <sub>x</sub> w <sub>x</sub>	6.5 Battery Weight + 5 %	
				Load Size		Working Aisle Width				
				Length	Width	intrusive	non-intrusive			
1400	420 Ah	1257	380	570	800	1200	2265	2490	opt. 1 1223x784x283	750
					1200	800	2665	2755		
					1000	1200	2465	2662		
					1200	1000	2665	2795		
	560 Ah	1325	312	502	800	1200	2333	2548	opt. 2 1223x784x355	939
					1200	800	2733	2817		
					1000	1200	2533	2722		
					1200	1000	2733	2857		
	700 Ah	1397	240	430	800	1200	2405	2610	opt. 3 1223x784x427	1119
					1200	800	2805	2884		
					1000	1200	2605	2786		
					1200	1000	2805	2923		
1600	420 Ah	1257	475	687	800	1200	2259	2490	opt. 1 1223x784x283	750
					1200	800	2659	2755		
					1000	1200	2459	2662		
					1200	1000	2659	2795		
	560 Ah	1325	407	619	800	1200	2327	2548	opt. 2 1223x784x355	939
					1200	800	2727	2817		
					1000	1200	2527	2722		
					1200	1000	2727	2857		
	700 Ah	1397	335	547	800	1200	2399	2610	opt. 3 1223x784x427	1119
					1200	800	2799	2884		
					1000	1200	2599	2786		
					1200	1000	2799	2923		
	840 Ah	1469	263	475	800	1200	2471	2673	opt. 4 1223x784x499	1306
					1200	800	2871	2951		
					1000	1200	2671	2850		
					1200	1000	2871	2989		
2000	560 Ah	1330	402	619	800	1200	2332	2552	opt. 2 1223x784x355	939
					1200	800	2732	2822		
					1000	1200	2532	2726		
					1200	1000	2732	2862		
	700 Ah	1402	330	547	800	1200	2404	2614	opt. 3 1223x784x427	1119
					1200	800	2804	2889		
					1000	1200	2604	2790		
					1200	1000	2804	2927		
	840 Ah	1474	258	475	800	1200	2476	2677	opt. 4 1223x784x499	1306
					1200	800	2876	2956		
					1000	1200	2676	2854		
					1200	1000	2876	2993		

Table 3 Axle load

ESR 4500-1.4 – 6090 TT-Mast with battery opt. 1

		without load			with load		
	Reach	front	rear	total	front	rear	total
2.4	extended	1607	1796	3403	807	3996	4803
2.5	retracted	2164	1239		1941	2862	

ESR 4500-1.6 – 7500 TT-Mast with battery opt. 3

		without load			with load		
	Reach	front	rear	total	front	rear	total
2.4	extended	1890	2103	3993	1037	4556	5593
2.5	retracted	2437	1556		2174	3419	

ESR 4500-2.0 – 9155 TT-Mast with battery opt. 3

		without load			with load		
	Reach	front	rear	total	front	rear	total
2.4	extended	2150	2373	4523	1042	5481	6523
2.5	retracted	2660	1863		2043	4480	

front = drive wheel  
rear = load wheels

Table 4

4.4 LIFT mm	4.2 CLSD mm	4.3 FREE mm	4.5 EXTD mm	ESR 4500 1.4	ESR 4500 1.6	ESR 4500 2.0
4440	2020	1510	4955	●	●	n.a.
4890	2170	1660	5405	●	●	n.a.
5340	2320	1810	5855	●	●	n.a.
5790	2470	1960	6305	●	●	n.a.
6090	2570	2060	6605	●	●	n.a.
6690	2770	2260	7205	●	●	n.a.
7140	2920	2410	7655	●	●	n.a.
7500	3040	2530	8015	●	●	n.a.
7950	3190	2680	8465	●	●	n.a.
8415	3350	2835	8930	○	○	n.a.
8850	3490	2980	9365	○	○	n.a.
9450	3690	3180	9965	○	○	n.a.
9900	3840	3330	10415	n.a.	○	n.a.
10230	3950	3440	10745	n.a.	○	n.a.
4145	2020	1400	4770	n.a.	n.a.	●
4595	2170	1550	5220	n.a.	n.a.	●
5495	2470	1850	6120	n.a.	n.a.	●
6395	2770	2150	7020	n.a.	n.a.	●
6845	2920	2300	7470	n.a.	n.a.	●
7205	3040	2420	7830	n.a.	n.a.	●
8120	3350	2725	8745	n.a.	n.a.	●
9155	3690	3070	9780	n.a.	n.a.	●
9605	3840	3220	10230	n.a.	n.a.	●
9935	3950	3330	10560	n.a.	n.a.	●
10835	4250	3630	11460	n.a.	n.a.	●
11435	4450	3830	12060	n.a.	n.a.	●

● = available ○ = opt. 1 battery comp. not available  
n.a. = not available

**Capacity**

At a 600 mm load centre:  
 Model ESR 4500-1.4 - 1400 kg  
 Model ESR 4500-1.6 - 1600 kg  
 Model ESR 4500-2.0 - 2000 kg

**Batteries / Electrical System**

48 V with nominal capacities of 420 to 840 Ah.  
 The battery is pulled out of the chassis with the reach carriage. The battery can be removed vertically or optional rollers can be provided allowing horizontal removal of the battery from either side.

**Standard Equipment**

1. Crown Integrated Control System with Access 1-2-3®.
2. Virtually maintenance free 3-phase (AC) motors for traction, hydraulics and steering.
3. Motor controllers for traction, hydraulics, and steering.
4. CAN-Bus technology.
5. 360 Select™ steering system allows the operator to choose between 180° and 360° steer tyre rotation.
6. Tilting steer column.
7. Proportional fingertip control for all hydraulic functions incorporating soft-lift/soft-stop for smooth load movement.
8. Information display
  - Access 1-2-3® onboard diagnostics with real time troubleshooting capabilities.
  - 2 line LCD display with 16 characters per line.
  - Hour meters for monitoring various truck operating components.
  - Travel direction indicator.
  - Input for operator PIN.
  - Real-time clock and date.
  - 3 selectable performance profiles.
  - Battery discharge indicator with lift lockout.
  - Steer wheel position indicator.
9. Thumb-operated travel direction switch.
10. Automotive type accelerator and brake pedal.
11. All-wheel braking.
12. Braking systems
  - Parking brake

- Mechanical service brake
  - Regenerative direction reversal
  - Regenerative coast braking
13. Electric switch for parking brake activation.
  14. Truck-Hold automatic braking for slopes or pushback racking.
  15. Electric power disconnect switch.
  16. Vulkollan load wheels and drive tyre.
  17. Four easy-access storage compartments.
  18. Comfortable knee and hip padding within the driver's compartment.
  19. Comfortable suspension seat with multiple adjustment possibilities.
  20. Patented offset, wide visibility mast with integrated hose reeving.
  21. Clear view overhead guard and load backrest.
  22. Lift slowdown prior to reaching full mast extension.
  23. Reach-out battery system.
  24. Reach carriage slowdown prior to reaching full extend or retract position.
  25. Integrated sideshift with tilting fork carriage.
  26. ISO class 2A forks.
  27. Battery plug DIN 160 Amp.

**Optional Equipment**

1. Integrated lift height and load weight indicator with truck performance linked to fork height.
2. Rack Height Select with automatic laden/unladen fork positioning starting 500 mm above secondary mast staging.
3. Free lift indicator, warning of fork heights above free lift. Can be programmed to reduce top travel speed.
4. Tilt position assist.
5. Dual-Axis hydraulic control levers (Standard on freezer trucks w/o cold store cab).
6. Lift cutout with/without override switch.
7. Lower cutout with override at a fork position just above the outriggers.
8. Mast or fork mounted camera with colour or B&W monitor.

9. Work lights 12/24 V.
10. Driving lights.
11. Battery rollers for horizontal battery extraction.
12. Flashing beacon.
13. Audible travel alarm.
14. Rearview mirror.
15. Power supply 12/24 or 48 V.
16. Davis Derby TruckLOG systems.
17. Work-Assist accessories – clipboard, scan gun holder, storage pockets.
18. 5th hydraulic function for add-on attachments.
19. Quad mast.
20. Overhead guard modifications for drive-in racking.
21. Cold storage conditioning for applications to -30° C.
22. Cold store cab.

**Driver's Compartment and Controls**

A comfortable step height, well-positioned grab handle, and non-slip floor mat ensure safe and comfortable footing during entry and exit.

Once seated, the operator has the ability to tailor the compartment to "fit". A high quality comfortable seat can be adjusted for the operator's weight. In addition, the seat can be adjusted laterally, as well as for the angle of the seatpad and backrest.

These adjustments, coupled with a tilting steer column, ensure a comfortable position for any operator. The left foot rests on the operator "presence" pedal. The right foot operates an automotive style accelerator and brake pedal arrangement, while the right leg is supported by ergonomically positioned padding for the knee and hip areas. The direction switch is actuated with the right thumb leaving the fingers of the right hand free to operate all the hydraulic controls. The fingertip control levers allow for easy blending of hydraulic functions and are easily understood by new or inexperienced operators. There are four easily accessible storage compartments. The ergonomically formed armrest is well padded and is designed particularly with wrist support in mind.

The display contains information on the truck's operating status, a battery discharge indicator, a travel direction indicator, steer wheel position indicator, hour meters for various truck operations, performance profile selection, and service information for planned maintenance scheduling, fault finding and testing. Coupled with a traditional keyswitch, the information display also serves as the PIN input for those choosing to employ the onboard user code system thereby preventing unauthorised use. The two line LCD display with 16 characters per line is well illuminated for excellent visibility. These standard features are complemented by information such as fork height and load weight indicators should these options be chosen.

A further panel is integrated into the chassis column and incorporates optional accessories such as light switches and Davis Derby TruckLOG system.

**Integrated Control System with Access 1-2-3®**

Crown's Integrated Control System provides unmatched truck control for all primary truck systems:

- Traction motor control
- Hydraulic valve and motor control
- Steer motor control
- Braking
- Information/diagnostic display

Dedicated motor controllers are employed to simplify troubleshooting and minimise replacement cost. All systems are linked through CAN-Bus, which greatly simplifies wiring while improving diagnostic communication.

On ramps, or when interfacing with push back racking, the selectable Truck-Hold feature electronically brakes the truck when the accelerator is released. The operator does not have to apply the brake, improving comfort and control in these applications.

Selected travel speed remains constant regardless of surfaces, load weight or grades. The travel speed, acceleration, and electric braking ratio can be set via the display, facilitating the best possible productivity and energy consumption for each application. Regenerative motor braking helps save energy.

The control system for the hydraulic pump motor and all proportional hydraulics facilitates precise and sensitive execution of all hydraulic functions. All hydraulic parameters such as lift, lower, tilt, sideshift, and reach speeds are fully adjustable and can therefore be adapted to different applications.

Crown's Access 1-2-3® Diagnostics is the most comprehensive fault detection system in the industry. A properly trained technician can actively view inputs and outputs during truck operation thereby significantly reducing search and downtime.

The information display is the first point for troubleshooting. All operator information such as travel and hydraulic parameters, truck monitors, etc. can be obtained and adjusted via the display. No handset or laptop is required – all functions are onboard and easy to use.

**Performance Profiling**

Three pre-set performance profiles can be selected on the display. The pre-set parameters can be changed to a multitude of other traction and hydraulic parameters allowing adaptation to each customer's requirements.

**Hydraulic System**

Proportional control ensures all hydraulic functions can be individually and precisely actuated regardless of load. Four hydraulic functions (lift/lower, tilt, sideshift, reach) are standard. A fifth function can also be provided. All hydraulic hoses are internally reeved through the mast.

The utilisation of an internal gear pump reduces the noise level and ensures high efficiency in all applications. The hydraulic oil is filtered twice. The return and suction filters can be exchanged without draining the hydraulic tank.

**Mast and reach carriage**

Crown's unique offset, wide view mast delivers excellent visibility at height as well as for low-level operations. Mast cross-bracing and overhead guard bracing have been angled, and hose and chain rollers have been canted to further enhance visibility. A load backrest designed for maximum visibility is also standard. The standard three-stage full free lift mast incorporates integrated sideshift with tilting carriage, hence reducing head length. Mast channels are reinforced to minimise static and dynamic deflection.

Spring dampers are located on the fork carriage to reduce noise while staging, and the lifting speed is slowed before reaching the lift limit. Elastomer dampers between the mast stages and hydraulic dampening in the free lift cylinder reduce noise while lowering.

The anti-friction mast rollers are canted to reduce energy consumption and ensure longer life. The heavy-duty reach carriage moves on four main roller bearings. Two adjustable backing rollers minimise dynamic mast rocking while four adjustable side rollers ensure very smooth movement and precise positioning.

**Drive unit**

A highly efficient drive unit with helical gears, integrated pinion and vertically mounted 3-phase (AC) traction motor provides quiet, powerful traction performance. A large Vulkollan drive wheel (343 x 140 mm) offers high load capacity, long life, and excellent travel comfort.

**Steering**

Advanced AC steering system featuring 360 Select™ control system that allows the operator to choose between 180° and 360° steer tyre rotation to match driving conditions, experience level or personal preference. The system can be locked in either mode with password-protected access. A fail-safe control circuit applies motor braking and parking brake if a fault is detected.

**Brakes**

The foot pedal applies the service brake. The brake pressure is distributed to the load wheels and the drive wheel by a master cylinder in combination with regenerative motor braking. This ensures the truck brakes smoothly and efficiently.

The parking brake is activated by a switch in the operator compartment. The spring-applied / electro-magnetically released brake is applied on the drive wheel. The parking brake is automatically applied when the operator exits the truck.

The truck can also be brought to a stop by reversing the travel direction using the electric regenerative plugging function.

Furthermore, the truck is equipped with an electric auto brake function, which stops the truck as the accelerator pedal is released (controlled coasting). Both electric braking functions can be set via the display.

**Motors**

All motors are highly efficient 3-phase (AC) which provide high available torque and seamless reversal. Traction and hydraulic motors are oversized for superior thermal capability and are especially suitable for high loads and high ambient temperature applications.

**Safety Regulations**

Conforms to European safety standards. Dimensions and performance data given may vary due to manufacturing tolerances. Performance is based upon an average size vehicle and is affected by weight, condition of truck, how it is equipped and the conditions of the operating area. Crown products and specifications are subject to change without notice.

